

IPv4-IPv6 transition

Just to cut the Gordian Knot?

Géza Turchányi, János Mohácsi ©
turchanyi.geza@gmail.com
mohacsi@niif.hu



Table of contents

- IPv4, IPv6 – two languages
- A borrowed slide – fix-mobile convergence
- About the authors
- Well known trends
- IP addresses (Trivialities 1)
- Two address saving methods and the weak points
- How the IP address allocation works for DSL?
- Let's find a wheel to reinvent
- Another wheel to reinvent
- Comparing proposals
- Summary
- Acknowledgement
- More to follow

IPv4 and IPv6 are two languages
...although the upper layer protocols are the same

My father told me a joke, a story, or an example if he
could not explain something otherwise

„The official language of this conference is English”

„Language officielle de cette conference est anglaise”

Translators?

Good news: Applications works the same way

Dreams Fix-Mobile convergence – a borrowed slide from the Ericsson’s tutorial „End to end IPTV Design”

Ericsson’s TV Vision of Converged Services and Service Creations

Why IMS ?

- Higher Scaling
- Standard Based Solution
- Service Delivery Platform
- Integration Ease
- Improved Useability

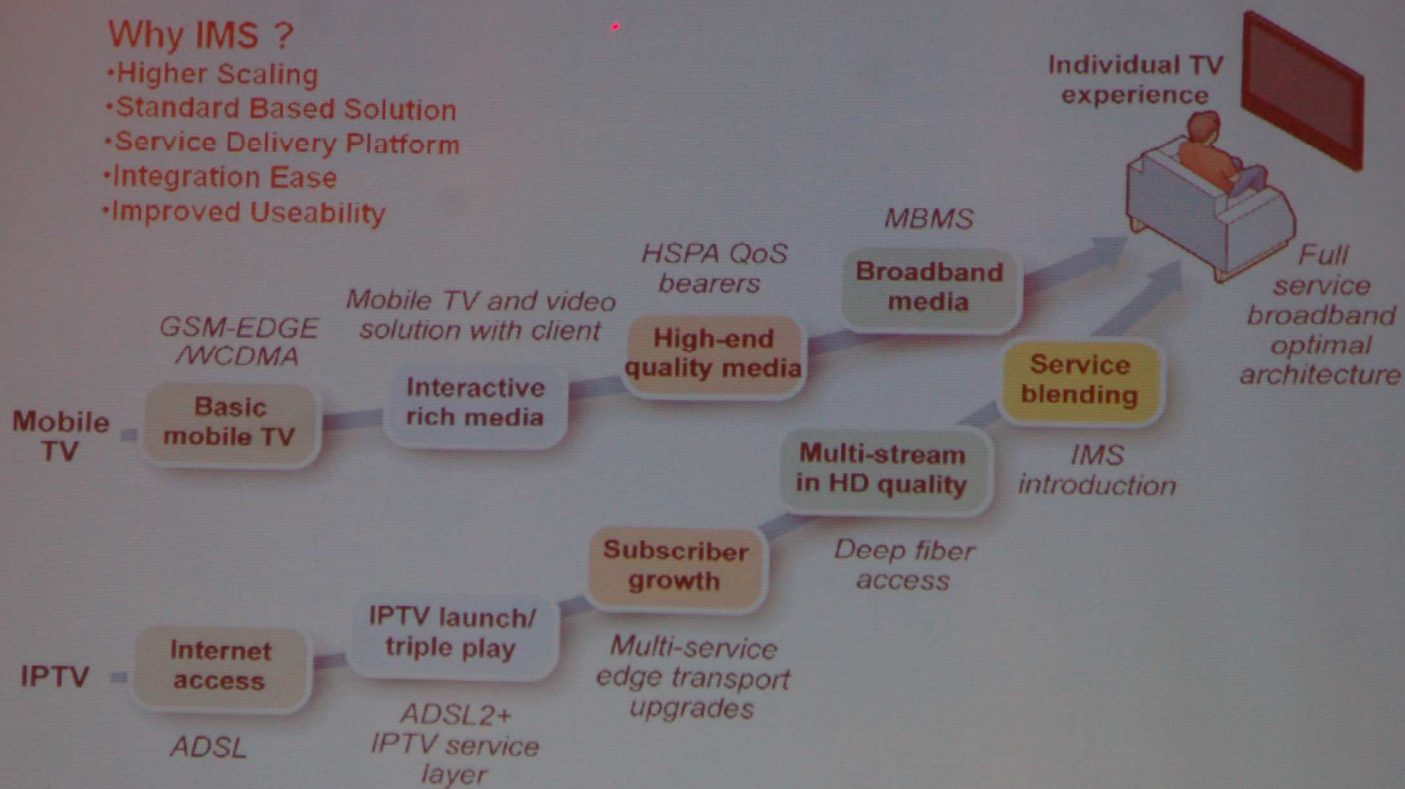

About the authors



János Mohácsi

CDO, National Information
Infrastructure Development
Institute (HUNGARNET, NIIF)

Computer engineer, 1993
Technical University of Budapest

DANTE (Cambridge) 2001-2002
EU/IST FP5/6/7 projects 2002-

IPv6: 6BONE, TIPSTER6
6NET, CampusIPv6
6DISS, 6Deploy

IETF: v6-ops, RFC4890

About the authors (2)

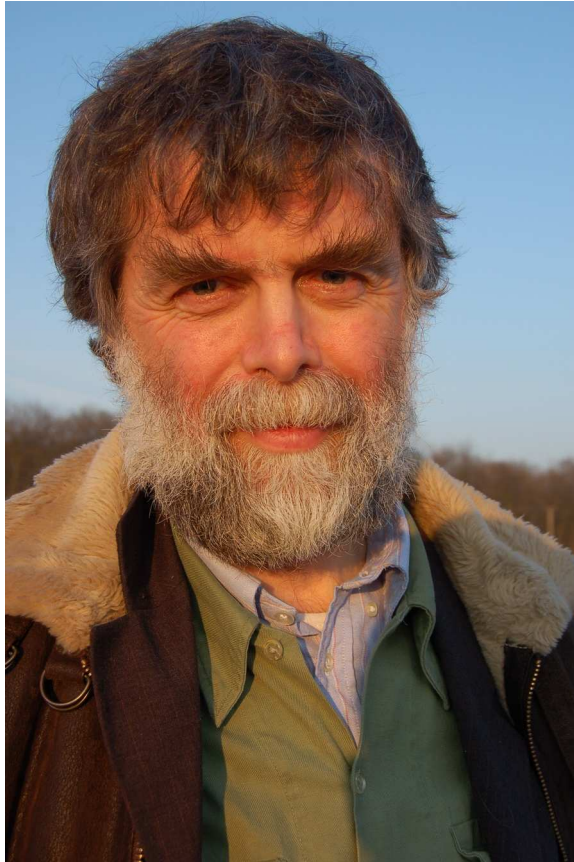

Géza Turchányi,
INFO-IPv6 Consulting

Mathematician, 1978
Eötvös Loránd University Budapest

CERN (Geneva) 1989-1991
RIPE NCC (Amsterdam) 1994

IPv6: RIPE-IPv6 wg (1996-)
TIPSTER6

IETF: contributor of RFC1918
v6-ops, draft-scopedAS

Well known trends (1)

IPv4 address space exhaustion: cautious scenario

Cautious: not to underestimate the problem

Tony Hain: (Internet Protocol Journal, Sept. 2005.)

A Pragmatic Report on IPv4 Address Space Consumption
(worst case scenario)

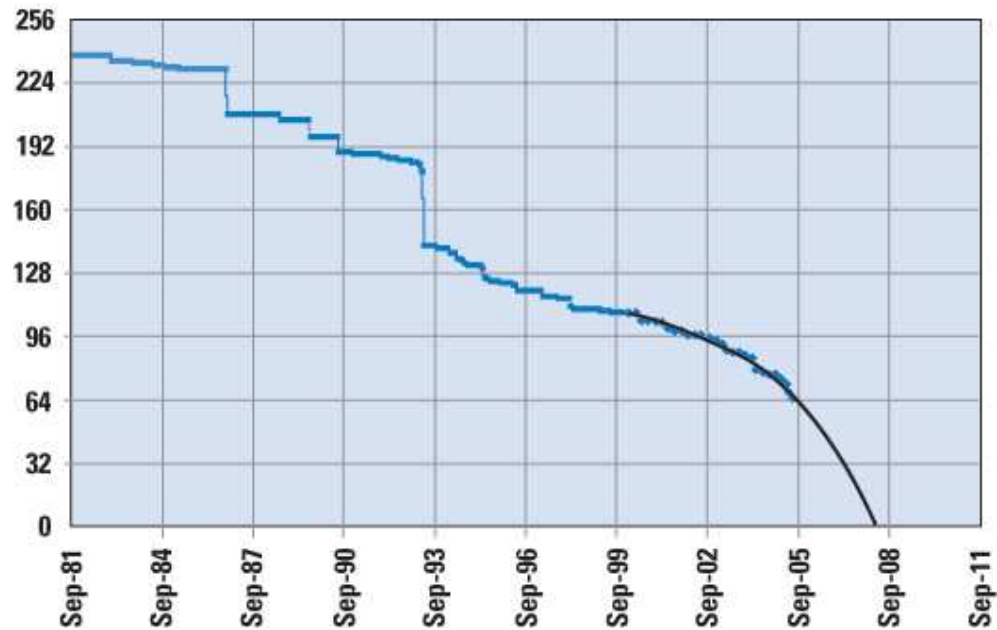

Well known trends (2) IPv4 address space exhaustion: trend analysis

Optimistic: not to overestimate the problem

Geoff Huston: www.potaroo.net/tools/ipv4/

Various mathematical methods in use

Updated daily. On 29. Sept. 2008:

**Projected IANA Unallocated Address Pool Exhaustion:
08-Nov-2010 (16-Apr-2010)**

**Projected RIR Unallocated Address Pool Exhaustion:
09-Nov-2011 (15-Feb-2011)**

However, in 2005, the estimated time was much longer!

IP addresses (trivialities)

IPv4: 148.6.0.5

(32bits, variable network/host boundary)

IPv6: 2001:0DB8:3003:0001:0000:0000:6543:210F

(128bits, 64bits network, 64bits host)

IP address allows:

- identification of a communication interface
- where to send the (groups) of packets (routing)
- backtracking (who has done, what, when)

Communication: IP address + port number (TCP, UDP)

Two address saving methods & weak points(1) Dynamic IP(v4) address allocation

Good old days: dial in	5 - 10%
Good old days: Broadband	- 50%
VOIP: (will) provoke semi-always-on!	->100%

Not enough address space left for massive always-on

even today!!

An Internet strike could hit almost all ISP!

(All dynamic users try to use the service at the same time)

Two address saving methods & weak points (2)

Reusable address space: Private AND AS-local

RFC1597: Address Allocation for Private Internets”, 03. 94

RFC1918: Next edition: February 1996

IANA reserved address blocks:

10.0.0.0/8 (old ARPANET space)

172.16.0.0 - 172.31.255.255 (172.16/12 prefix)

192.168.0.0 - 192.168.255.255 (192.168/16 prefix)

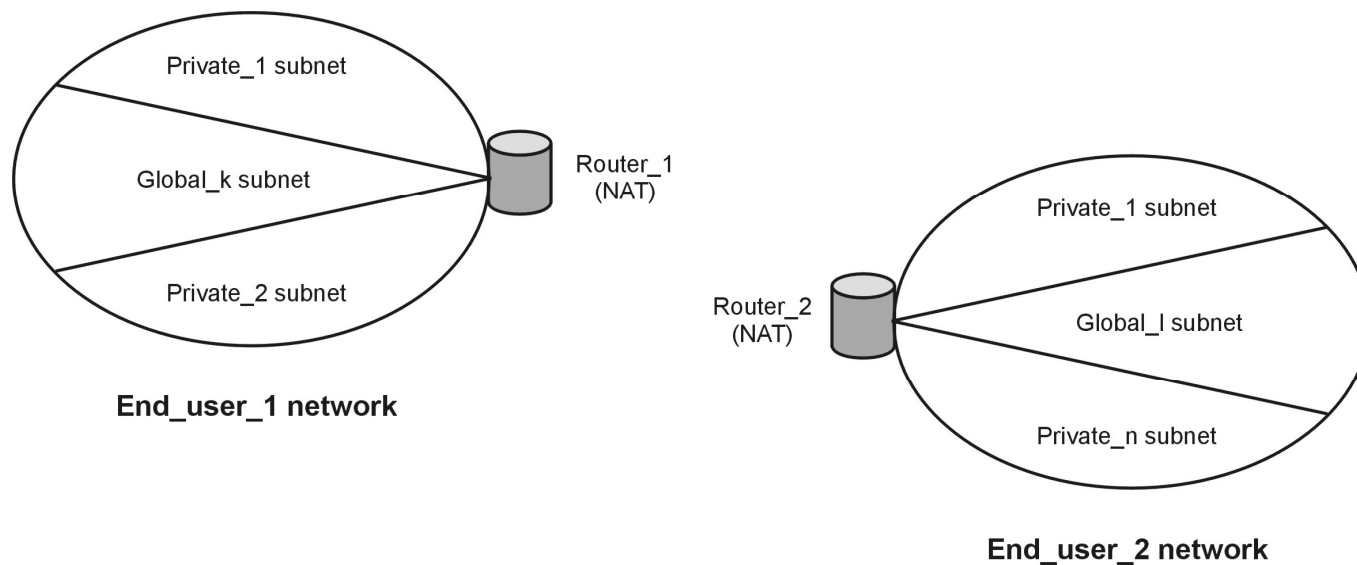

How the IP address allocation works for DSL?

Still like dial-in via a modem (PPP)...

It is easy to assign an IPv4 address to a DSL user, however, how to assign an IPv6 address (or: an IPv6 network) ?

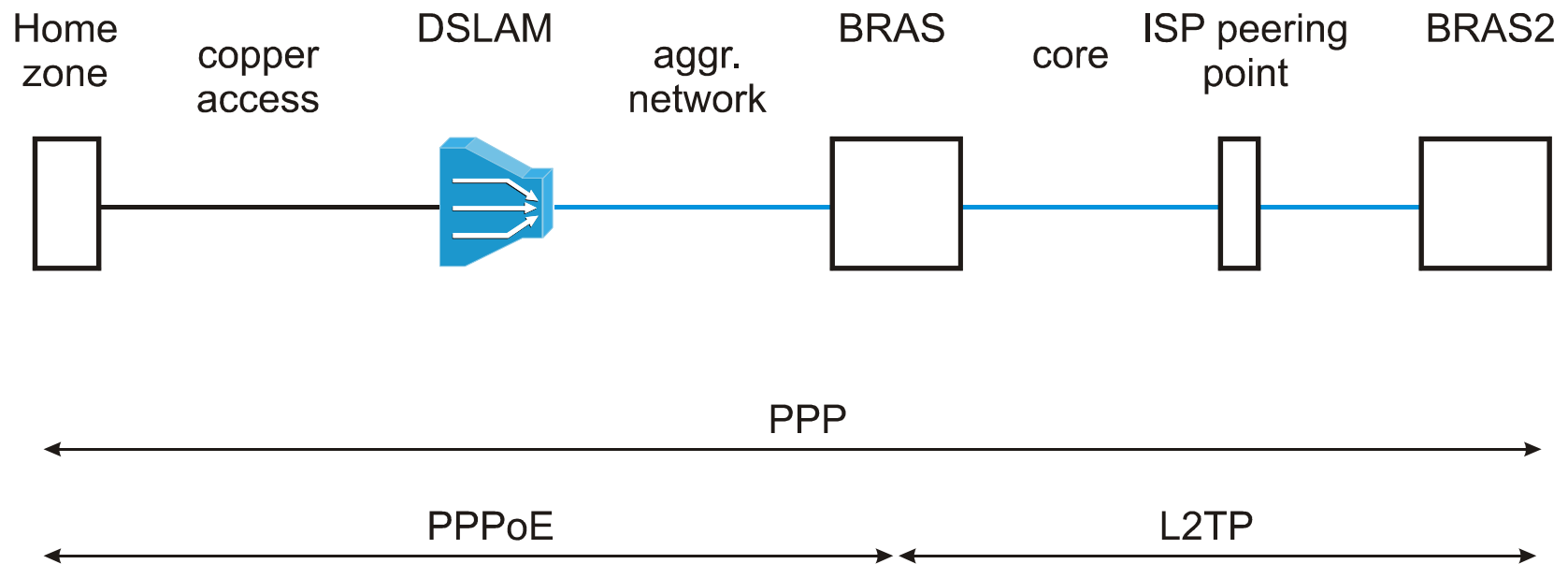

Let's find wheels to reinvent (1) (6to4, Brian Carpenter)

Having an IPv4 address, it is easy to create an IPv6 network

Select a prefix: 2002 (for 6to4, RFC3056 and RFC3068)
Extend it: IPv6prefix_ext=f(IPv4) f(x)=x
... and use as the network prefix!

The IPv6 packets can even be tunnelled over IPv4!
6to4 is about Ipv6 address allocation and routing

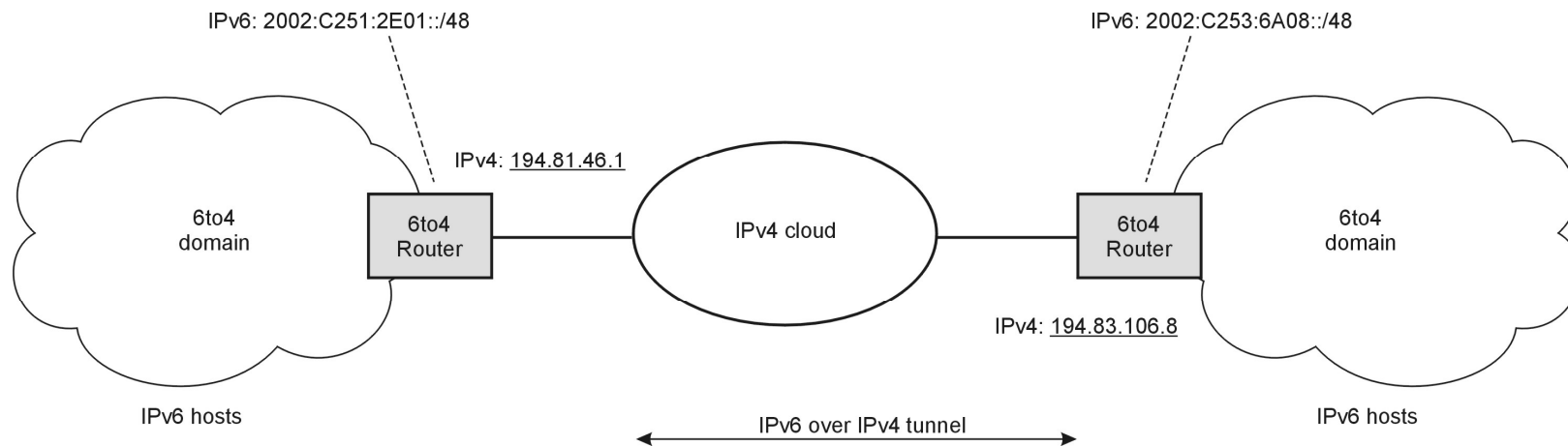

Let's find wheels... (2): 6to4 limits How to find a solution for DSL users?

6to4 is good example how to assign IPv6 networks, however
what to do, if there is not enough IPv4 addresses?

Our IPv6DM proposal at RIPE 55th 25. Oct. 2007:

[//www.ripe.net/ripe/meetings/ripe-55/](http://www.ripe.net/ripe/meetings/ripe-55/)

[presentations/turchanyi-two-jokes-half-proposal.pdf](#)

Use unique IPv6 prefix assigned for this purpose to the ISP
Global IPv4 and AS-local reusable IPv4 address space
Simple mathematics for the prefix calculator function

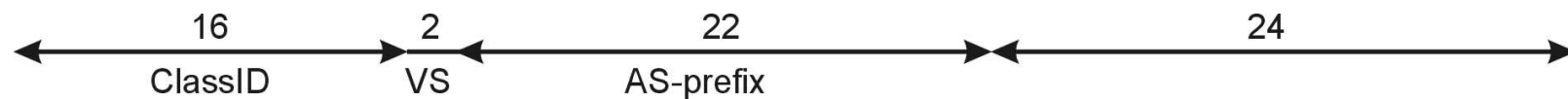

Rémi Deprés submitted the (RD) draft RFC, 9. Feb. 2008:

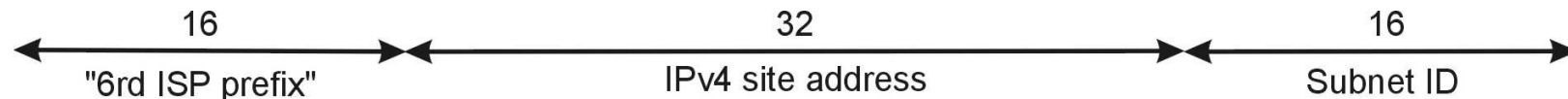

An other wheel to reinvent: reusable address space

New reusable address class: AS-local

Details in [Draft-scopedIPv4AS-00](#)

www.ripe.net/ripe/meetings/ripe-55/presentations/turchanyi--two-jokes.pdf

Similarities with private IP addresses, BUT

Scope: Autonomous System (AS), Internet Service Provider

Routable within the AS

Allocated by IANA and contributors

For dynamic allocation, might be revoked

Dark address space might be part of it

Comparing similar proposals (1)

IPv6 address assignment based on IPv4 address assignment

Original

Brian Carpenter: 6to4

Good for static global IPv4 addresses, fix prefix: 2002

Reinvented first: IPv6DM (Géza Turchányi, János Mohácsi)

Tailored to reusable IPv4 addresses, dedicated prefix for the ISP

Projecting IPv4 address space into IPv6 address space, efficient

Reinvented again as RD by Rémi Després

Tailored only to a medium-sized ISP (Free in France)

CPE must have in hand

Need huge IPv6 address space, inefficient, but simple

Well documented, draft RFC

Comparing similar proposals (2)

New reusable address space

Original: Address Allocation for Private Internets; RFC1597, 1981
Classful, non-scoped IPv4 address ranges
Good for sites, client-only access

Reinvented first as AS-local (Géza Turchányi)
Presented first at Networkshop March 2007, then at RIPE 55th
Address blocks can be added and revoked
IANA and contributor ISP

Reinvented as ISP-local
Draft-shirasaki-isp-shared-addr-00.txt
IANA allocated only, coupled with carrier-grade NAT
Well documented, draft RFC

Reuse 240/4 ???
no support in the widespread operating system

Summary

There is a bottleneck of IPv4->IPv6 transition is in the DSLAMs and around.

New protocols and standards needed urgently

Included:

A new, reusable IPv4 address class (AS-local)
IPv6 address class: calculated from IPv4 dynamic addr.

Content provision in IPv6 – no time to wait

Acknowledgement

Ruediger Volk (Deutsche Telekom)

Attila Balogh (Magyar Telekom)

More to follow

IETF www.ietf.org

RIPE www.ripe.net

DSL Forum ???

Many thanks for your attention!

Je Vous remercie votre attention!

Questions?

info@info-c.hu

Extension – more about RD

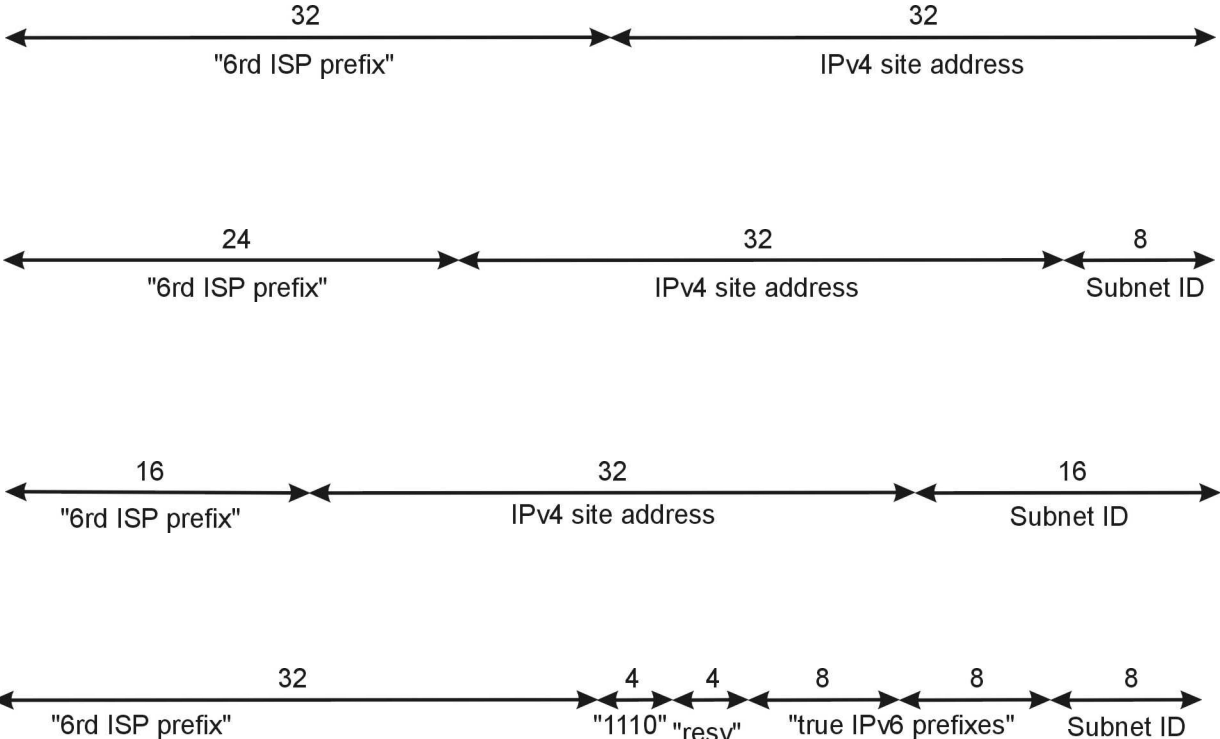

Extension – more about IPv6DM

